



SHOGUN

EB5 Display Manual

Index

1: Preface	2
2: Material&Dimension	3
Material and color	错误!未定义书签。
Physical view	错误!未定义书签。
Dimension	4
3:Functions	4
4:Buttons definitions	6
5:Installation	错误!未定义书签。
6: Operation	错误!未定义书签。
(1)On/Off	8
(2)Lighting and background light On/Off	9
(3)Assistance Level adjustment and 6kn/h assistance	9
(4)Display UI	10
(5)Battery capacity	12
(6)Error code	12
(7)Clearing	14
7:Common setting	13
(1)Password Input	13
(2)Max assistance level	13
(3)Wheel size	13
(4)Speed unit	16
(5)Speed limit	16
8:Wiring digram	17
9:FAQ&Answers	16
10:Guarantee&Warranty	16
Coverage:	16

Exemption:	17
11:Version	17
Attachment: Error code definition	19

1. Preface

Dear Customer, we ask you please kindly study this manual for D10 PC5/ D10 PU5 to use your electric bike better. We will try to present you necessary information from installation, setting and normal use in most clear words, and hope it helps to clear your possible confusion or problems.

2: Material and dimension

Screen size of D13/U is 52.5mm in length and 33.3mm in width, it has 3 buttons for control, the display characterizes in light and artful view, clear UI, Dual-layer PCB. Mounting bracket is made of Nylon, and the cover is made of ABS, which guaranteed compatibility to environmental temp.ranging from -20°C to 60°C, while remains excellent mechanical performance.

Physical view

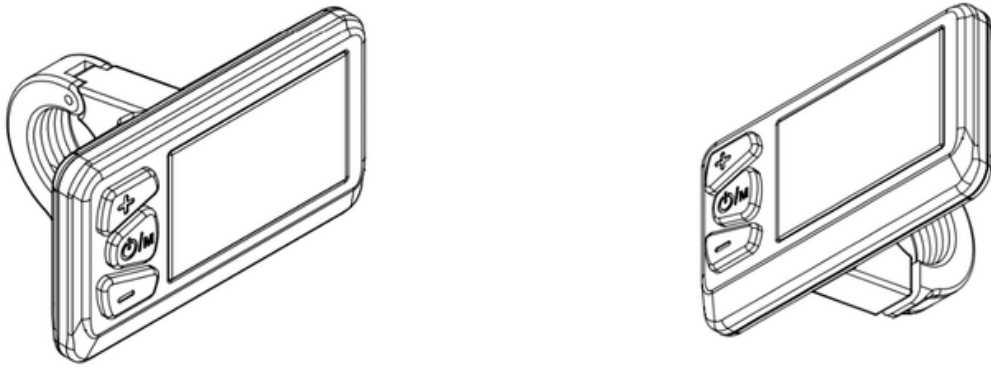

2-1

Dimension (mm)

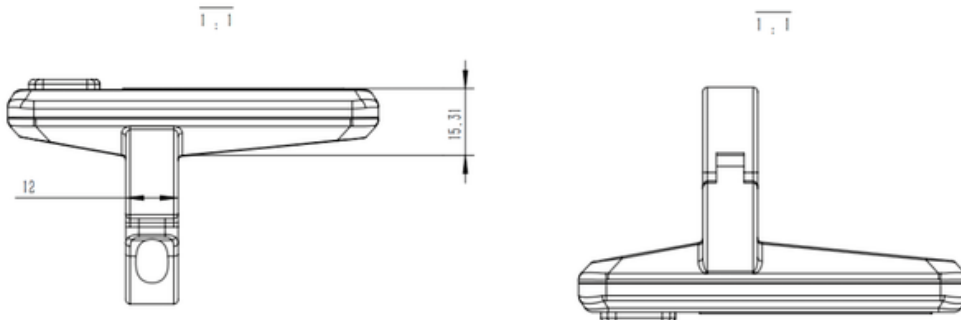



图 2-2

3: Functions

D13/U is a LCD display of 2.4", compatible for 24V/36V/48V batteries, integrating front light. Functions listed as below

- ◆ ODO;
- ◆ Trip;
- ◆ speed;
- ◆ Lighting;
- ◆ Assistance level;
- ◆ Battery capacity;
- ◆ Error code;
- ◆ Unit shift(KM/H, MPH);
- ◆ Wheel size setting;
- ◆ Trip time;

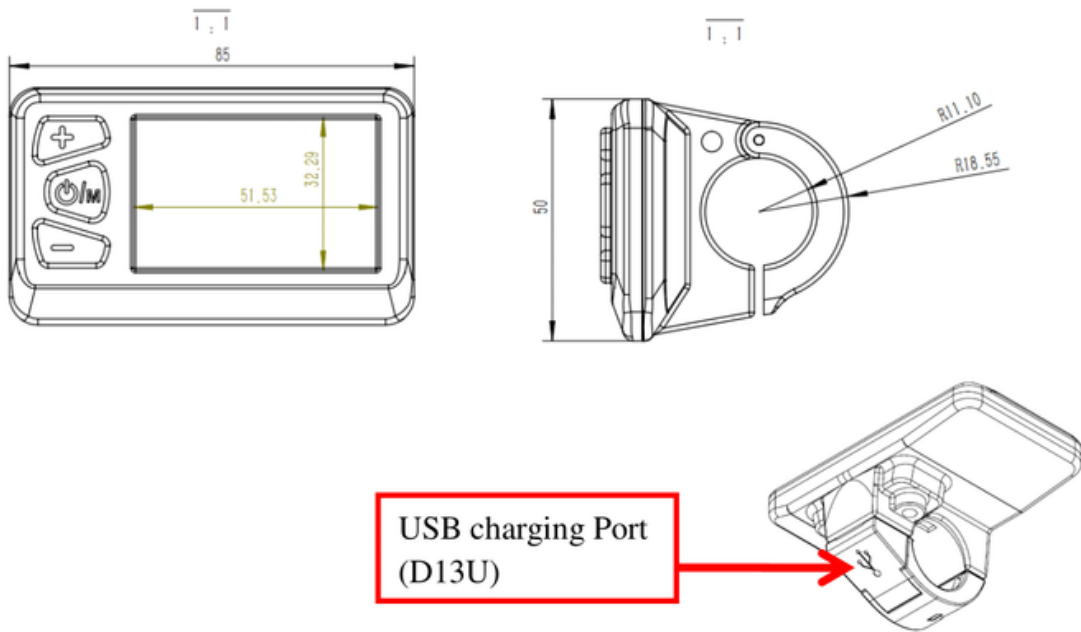
- ◆ 6Km/h assistance level;
- ◆ USB charging: 1A (Only for D13U)



图 3-1

UI View

Complete UI display contributes for artistic view and helps the rider to get all necessary information as below Pic shows:

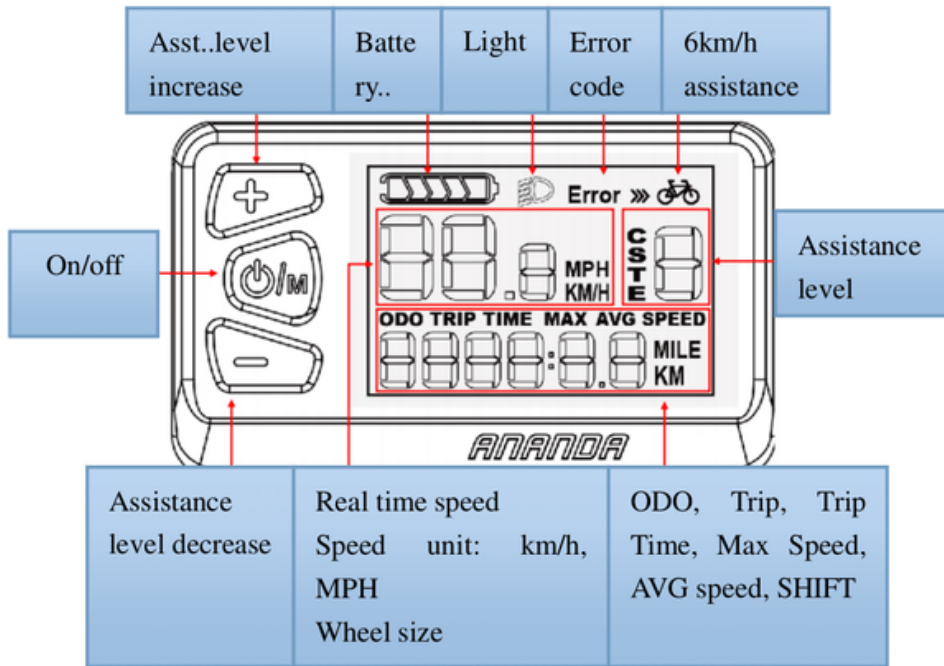

图 3-2

UI@ON

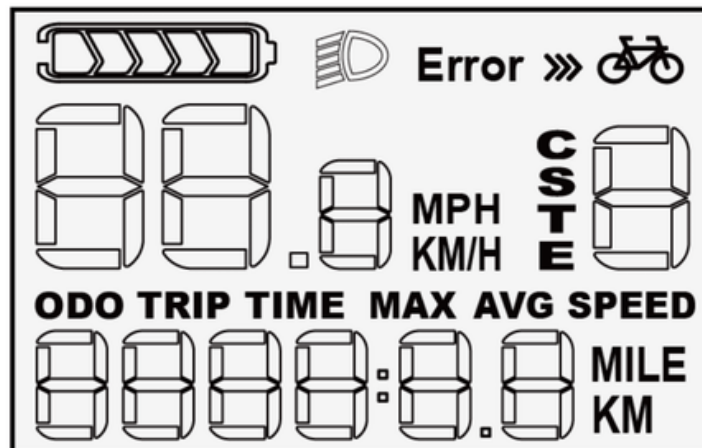

图 3-3

4: Buttons definition

D13/U has 3 buttons namely PLUS, ON/FF, MINUS

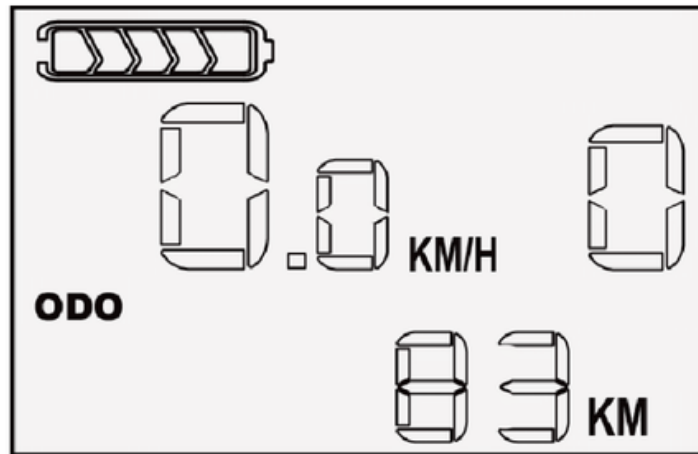

图 4-1

5: Installation.

Fix the display around the handle bar, adjust it for a better view angle and easy accessibility, then fasten the screw to complete installation.

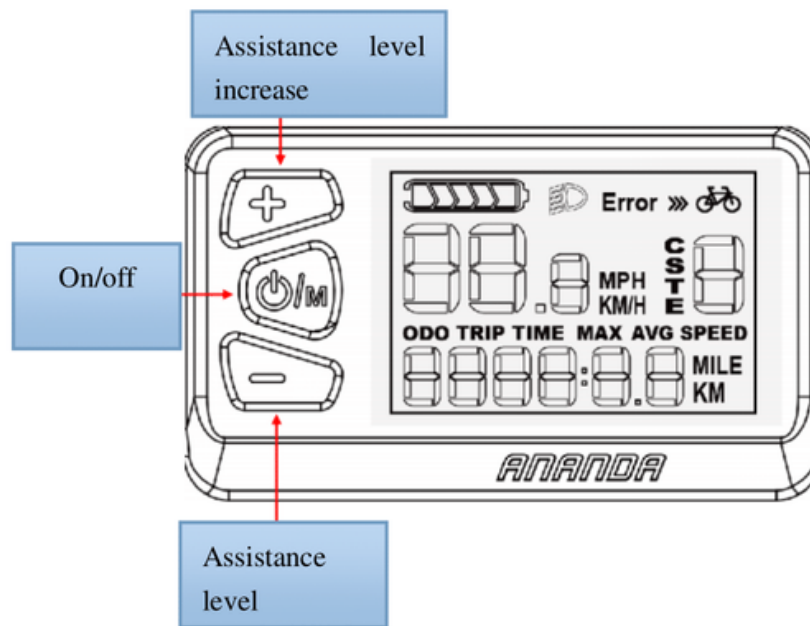

Fix the bracket to handle bar

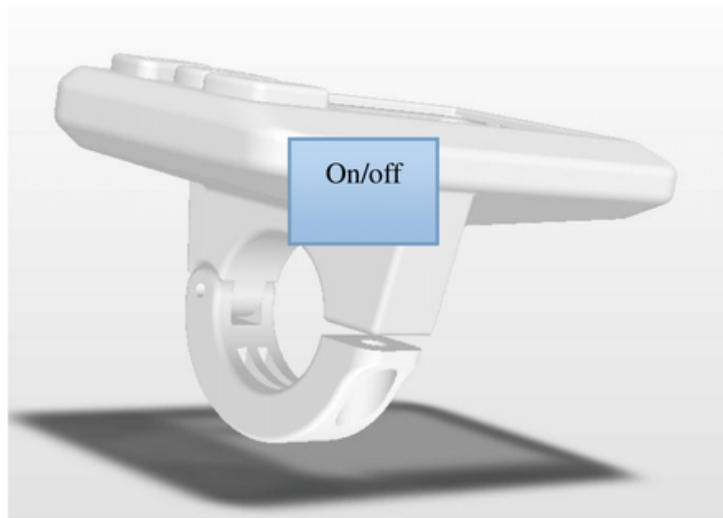

Fasten the screw

6: Operation

(1) ON/OFF

Hold on ON/OFF for 1s to switch on the display and activate controller;
Hold on ON/off for 2s when display is on will switch it off, display no longer consumes battery at this mode and the leak current is below $2\mu\text{A}$, Operation procedure:



图 6-1

(2)、 Front and background Light ON/OFF

Hold on plus button or 2s when display is on will turn on front light and background light is off. Hold on plus button for 2s again will turn off front light, and background light is on.

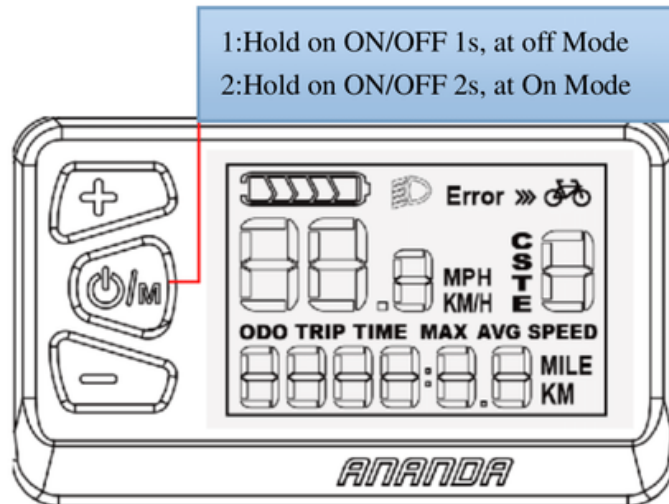

图 6-2

(3) Assistance level adjustment and 6KM/H assistance

Shortly press Plus or Minus button to adjust assistance level when display

is turned on. Default output is set to 5 or 9 levels. Press & Hold on minus button will activate 6km/h assistance at any output level, but motor output is cleared as 0 automatically; Release Minus button to cancel 6km/h assistance, output. E.g.: (6Km/h assistance is activated at Level).

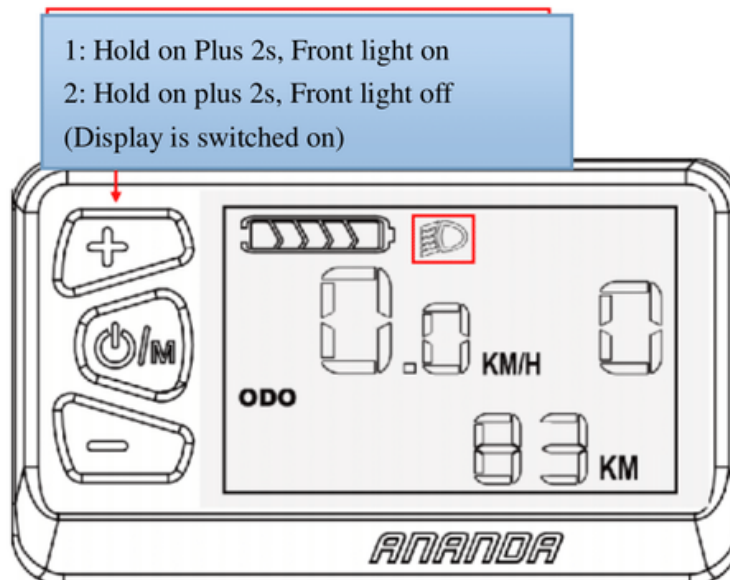

图 6-3

(4)、Screening

PCB detects speed and transfer to screen for displaying when EPAC is running. Rotation input is transmitted to controller, which adjust motor RPM, and feedback motor speed to display and show Real time speed, ODO, Trip, Time, Max Speed, AVG speed, Assistance level, Battery Capacity, Error code etc.

There are two units option for speed including MPH and KM/H, which is

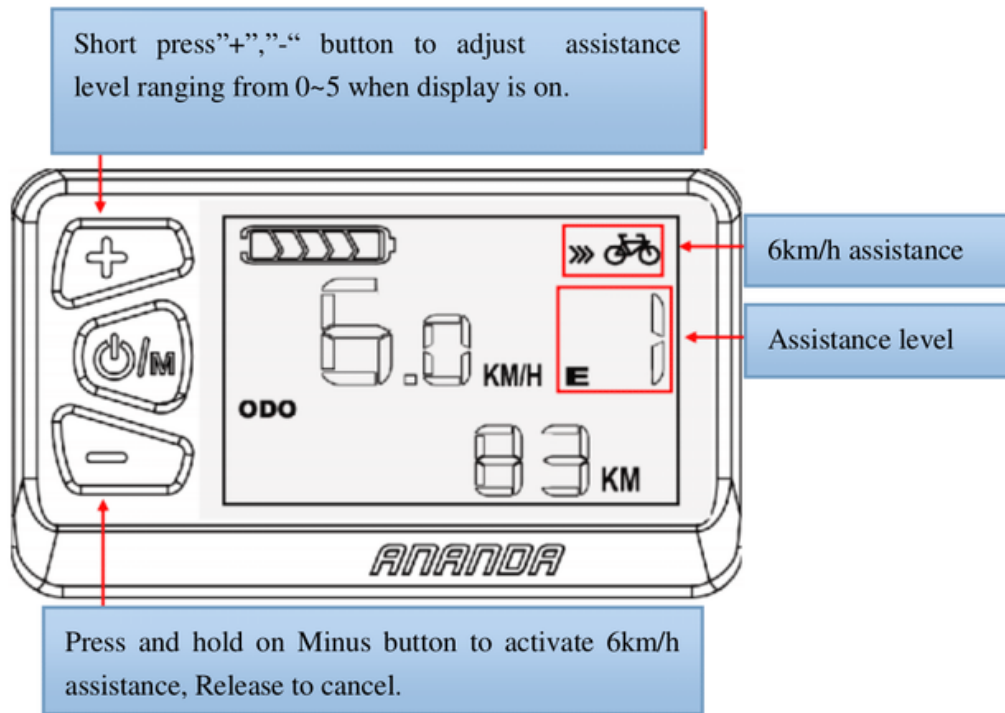
shifted in setting mode (See section 7), Please Kindly note in reality, only one option is showed as below Pic 6-4, which is only for illustration.



图 6-4

ODO, Trip, Time, Max speed, AVG speed could be showed by shift as long as display is on. Default UI for display activation is set to one when it is turned off. Short press for 0.5s to shift to other UIs, following sequence of ODO->TRIP->TIME->MAX->AVG->ODO as a cycle. Illustrated as below: (83km ODO for example only.)

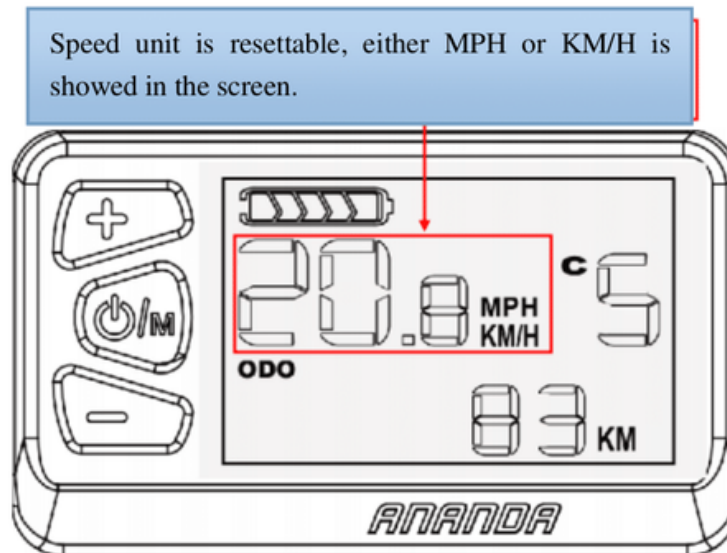

图 6-5

Battery capacity(5 Columns for now):

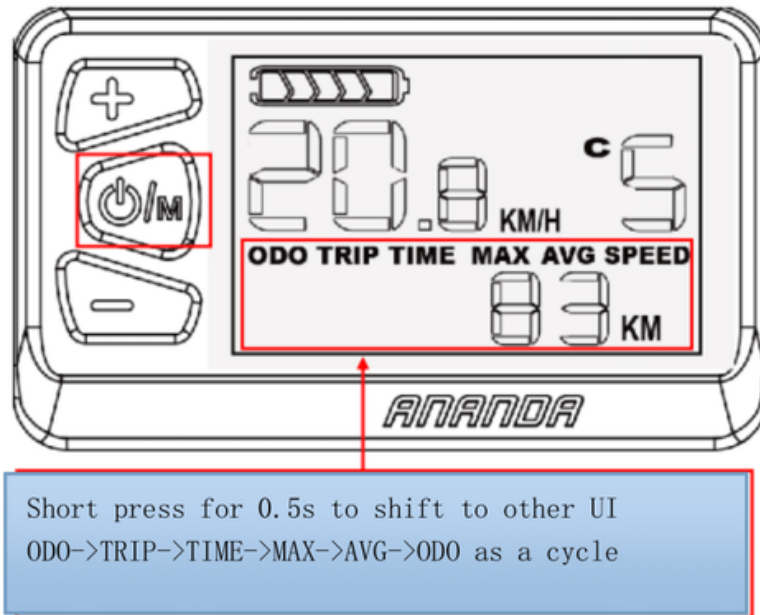

图 6-6

(5)、Battery capacity

All five columns lights on if battery fully charged; if battery is under voltage, last column blinks, charging is needed

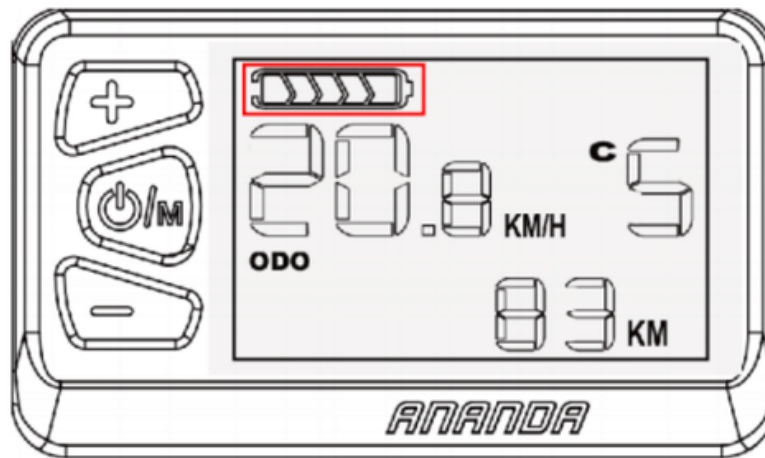

图 6-7

Percentage:

5%—25% 1st column

25%—45% 2nd column

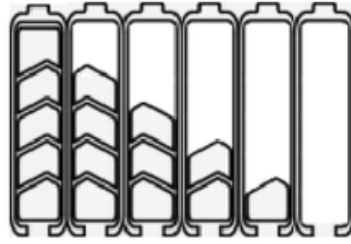
45%—65% 3rd column

65%—85% 4th column

85%—100% 5th column

(6)、Error code

Display will show an error code if ECU has a problem, and the code blinks, system stops working. UI will not quit from the error code mode until error code is cleared(Re-starting does not work until error code is cleared), Please refer to attached error code definition for further information. Error code UI as below6-8:



图 6-8

(7)、Clearing:

Hold on plus and minus button at same time for over 3s will clear all information under the UI of trip, time, max, Avg.

7、Common setting

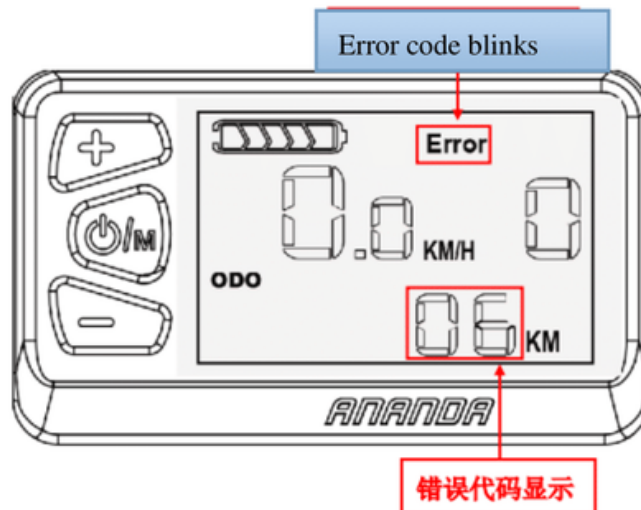
(1) Password input

Hold on plus button for over 10s at home UI when speed is zero will activate password input for resetting, then short press plus button to shift among 0->1->2->3->4->5->6->7->8->9->0 for input; Shortly press minus button for digit movement from left-right-left in a cycle, shortly press on/off for 0.5s after input the UI of Menu. If the password (6262) is wrong, it will do back to home UI. If password is input correctly, display will keep it automatically unless last input was wrong or battery is cut off at the operation. Password input UI illustrated as 7-1:

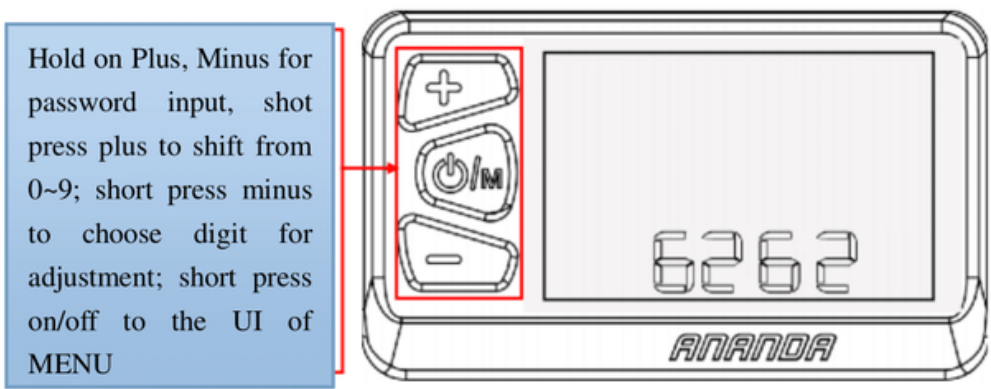

7-1

Short press on/off at Menu UI to shift among Max assistance level, wheel size, KM/MPH, Speed limit, Version.....Max assistance level.

(2)Max assistance level

Short press minus button to choose Max assistance level(5 or 9),Shortly press On/off for 0.5s to save and quit; If no operation at this UI for over 10s, it automatically returns to home UI.

(3)Wheel size

Options available at wheel size UI are: 16、 18、 20、 22、 24、 26、 27.5、 28 inches. Press plus or minus to choose corresponding wheel size to guarantee speed and range accuracy. Shortly press on/off for 0.5s to quit and save. It automatically returns to home UI if no operation for 10s.Wheel size setting illustrated as below: (24 for example only)



图 7-2

(4)Speed unit

Speed unit (KM/H, MPH) is adjustable by short pressing minus button at unit setting interface. Shortly press ON/OFF for 0.5s to save and quit. It automatically returns to home UI if no operation for 10s.Eg:

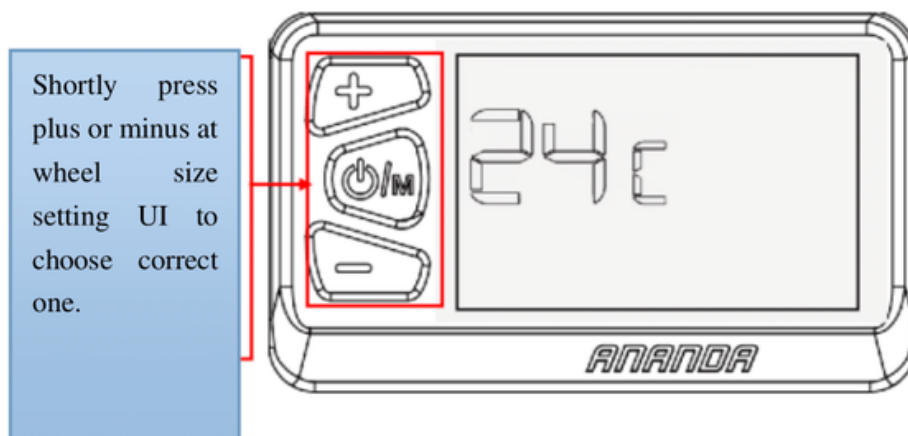

图 7-3

(5)Speed limit

At speed limit UI, short press plus or minus button to adjust speed limit; shortly press on/off for 0.5s to save and quit. It automatically returns to home

UI if no operation for 10s. Default set is 25km/h illustrated as 7-4 (12Km/h for example):

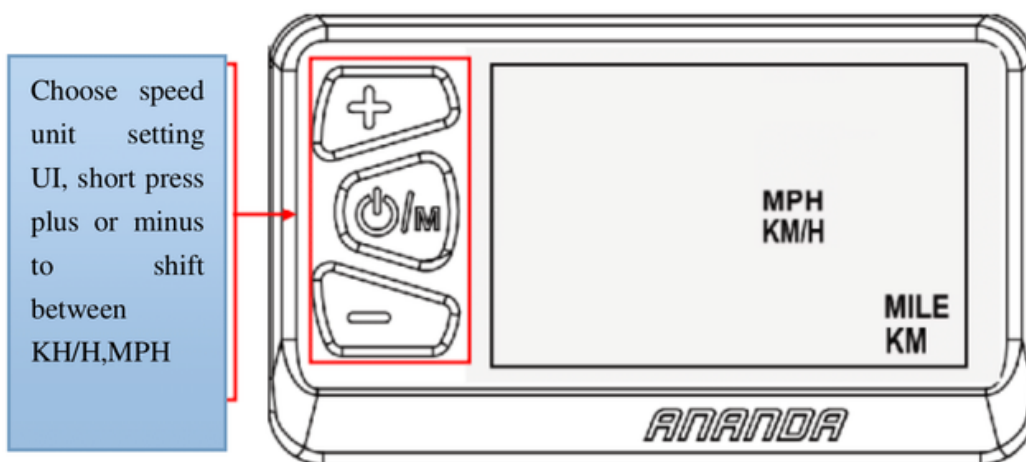

图 7-4

8:Wiring diagram

D13/U has a 5 pin wiring, is compatible for 这 24V/36V/48V battery, definition for them are +,-,5v,R,T.

9:FAQ and answer

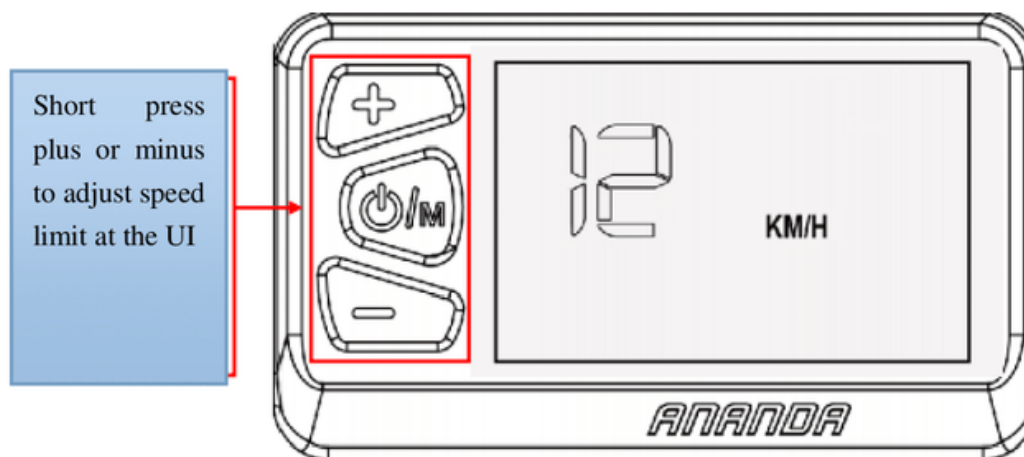
Q: Cannot turn on

A: Check if connection between controller and display well.

A: Error code seen

A: Find definition of the code; send it to authorized store for maintenance if not solvable.

10: Guarantee and warranty

Coverage:

(1) We offer limited warranty as long as it is under guarantee coverage for

quality issues.

(2) Guarantee valid for 30 months from EXW.

Exemption:

- (1) Unauthorized dismantling or modification.
- (2) Damage or defects caused by misuse or improper assembling.
- (3) Scratches or crack in cover after distributed.
- (4) Cable scratches or crack after distributed.
- (5) Any damage or defects caused by force majeure.
- (6) Out of warranty.

11: Version

Please refer to the one in use in your hand should there be any discrepancy between each version.

Version number is available by long pressing plus button for 10s at home UI when speed is zero, after inputting password, short press on/off button to version information to get it. Eg:11 :



图 11

Attachment: Error code definition

D13UART ERROR CODE (hexadecimal)	Definition	Solution
21	Phase wire over current	restart the system, if continues please apply for warranty and authorized dealer
22	brake ON	check if brake recovered before system is on or brake cable is ok
24	HS failure	Check if cable well connected, if continues after reconnection please ask for help of authorized dealer

28	other failures	reconnect & restart the system, or update program or replace controller
30	communication error	Restart the system; check cable connection
31	battery switch failure	check if battery key ON/OFF
32	push assistance failure	check button stuck or not
33	MCU failure, base voltage failure	replace display

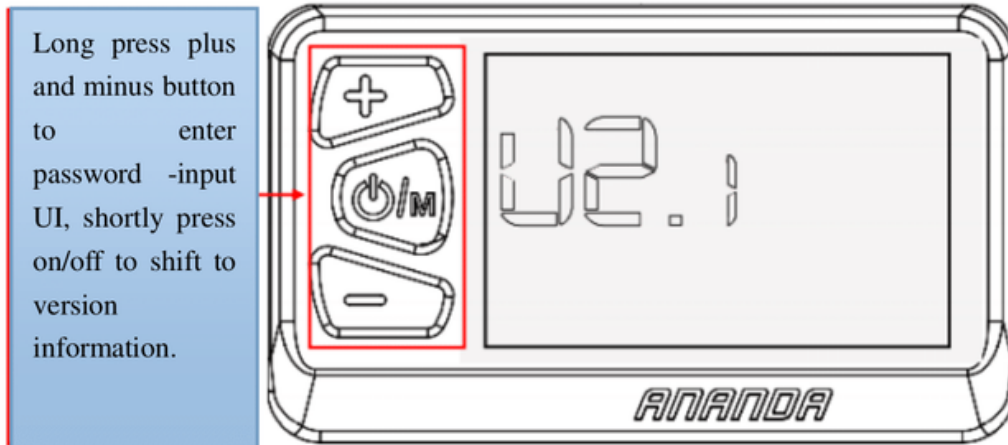

SHOGUN

EB5 Display Manual